

Bimetal thermometer

For industrial applications

Models A52,R52

WIKA data sheet TM 52.01



for further approvals
see page 6

Applications

- A wide range of applications in machine building, vessel, piping and apparatus construction
- Heating technology

Special features

- Scale ranges from -30 ... +500 °C
- Large choice of nominal sizes from 25 ... 160 mm
- Case and stem from stainless steel
- 5 different connection designs



Fig. left: model A52.100, back mount

Fig. right: model R52.100, lower mount

Description

The model A52, R52 bimetal thermometers are the entry-level model among process thermometers. The target markets of this thermometer are air-conditioning and machine building.

Model 52 is manufactured in accordance with EN 13190 and already offers a stainless steel case and accuracy class 1 for nominal sizes > 60 mm.

Especially noteworthy is the large number of stem lengths and nominal sizes. This enables the individual adaptation to the target applications.

Specifications

Measuring element

Bimetal coil

Nominal size in mm

25, 33, 40, 50, 63, 80, 100, 160

Connection designs

S Standard (male threaded connection)

1 Plain stem (without thread)

2 Male nut ¹⁾

3 Union nut ¹⁾

4 Compression fitting (sliding on stem) ¹⁾

other connection designs on request

Model overview

Model	NS	Design
A52.025	25	Back mount (axial)
A52.033	33	
A52.040	40	
A52.050	50	
A52.063	63	
A52.080	80	
A52.100	100	
A52.160	160	
R52.063	63	Lower mount (radial)
R52.080	80	
R52.100	100	
R52.160	160	

Unit (scale range)

°C

Option: °F, °C/°F (dual scale)

Accuracy class

NS 25, 33: ±5 % of scale range

NS 40, 50: 2 per EN 13190

NS 63, 80, 100, 160: 1 per EN 13190

Working range

Continuous loading: Measuring range per EN 13190

Short time (24 h max.): Scale range per EN 13190

Case, bezel ring, stem, process connection and spacer

Stainless steel

Elbow behind the case

Aluminium, only with lower mount version

Dial

Aluminium, white, black lettering

Pointer

NS 25, 33, 40: Aluminium, black

NS 50, 63, 80, 100, 160: Aluminium, black, adjustable pointer

Window

Instrument glass

NS 33: polycarbonate

Permissible operating pressure at the stem

NS 25, 33, 40, 50: max. 6 bar, static

NS 63, 80, 100, 160: max. 25 bar, static

Ingress protection

NS 25, 33, 40: IP54 per IEC/EN 60529

NS 50, 63, 80, 100, 160: IP43 per IEC/EN 60529

1) Not for NS 25, 33, 40, 50

Scale ranges, measuring ranges ²⁾, error limit (EN 13190)

Scale graduation per WIKA standard

Scale range in °C	Measuring range in °C	Scale spacing in °C		Error limit ±°C	
		up to NS 63	from NS 80	up to NS 50	from NS 63
-30 ... +50	-20 ... +40	1	1	2	1
-20 ... +60	-10 ... +50	1	1	2	1
0 ... 60	10 ... 50	1	1	2	1
0 ... 80	10 ... 70	1	1	2	1
0 ... 100	10 ... 90	2	1	2	1
0 ... 120	10 ... 110	2	1	4	2
0 ... 160	20 ... 140	2	2	4	2
0 ... 200 ³⁾	20 ... 180	5	2	4	2
0 ... 250 ³⁾	30 ... 220	5	2	5	2.5
0 ... 300 ⁴⁾	30 ... 270	5	2	-	5
0 ... 400 ⁴⁾	50 ... 350	5	5	-	5
0 ... 500 ⁴⁾	50 ... 450	5	5	-	5

2) The limits of the measuring range are indicated on the dial by two triangular marks.

Only within this range is the stated error limit valid per EN 13190.

3) Not for NS 33

4) Not for NS 25 to NS 50

other scale ranges on request

Connection designs

Standard design (male thread connection)

Standard insertion length $l_1 = 63, 100, 160, 200, 250$ mm

Nominal size	Process connection		Dimensions in mm		
	G	i	SW	Ø d ₄	Ø d
25, 33	M8 x 1.25	8	12	-	4
	G 1/8 B	8	12	-	4
	G 1/4 B	8	17	-	4
40, 50	M8 x 1.25	8	12	-	4
	G 1/8 B	8	17	-	4
	G 1/4 B	8	17	-	4
	G 1/2 B	12	22	-	4
63, 80, 100, 160	G 1/4 B	12	19	18	6 or 8
	G 1/2 B	14	27	26	6 or 8
	M18 x 1.5	12	24	23	6 or 8
	1/2 NPT	19	22	-	6 or 8

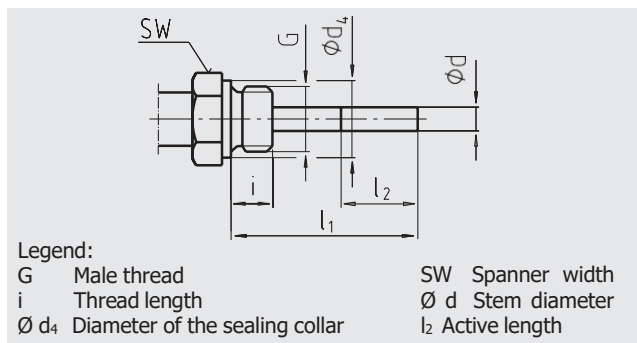

Design 1, plain stem (without thread)

Standard insertion length $l_1 = 45, 63, 100, 140, 160, 200, 240, 290$ mm

Nominal size	Dimensions in mm	
NS	d_1	$\varnothing d$
25, 33	8	4
40, 50	12	4
63, 80, 100, 160	18	6 or 8

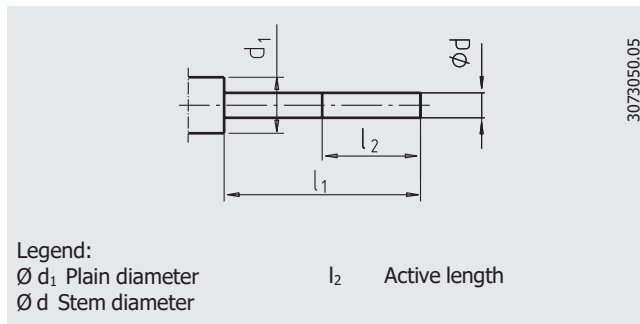

Design 2, male nut

Standard insertion length $l_1 = 80, 140, 180, 230$ mm

Nominal size	Process connection		Dimensions in mm	
	G	i	SW	$\varnothing d$
63, 80, 100, 160	G 1/2 B	20	27	6 or 8
	M18 x 1.5	17	22	6 or 8

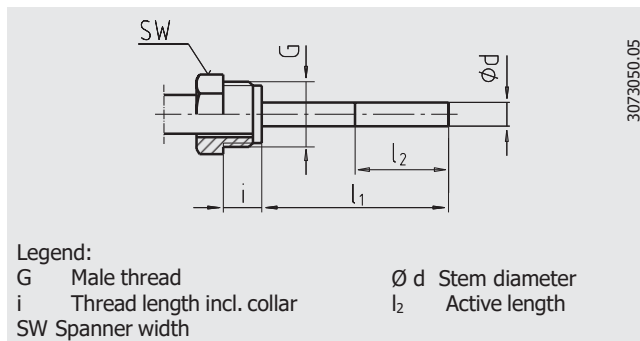

Design 3, union nut

Standard insertion length $l_1 = 89, 126, 186, 226, 276$ mm

Nominal size	Process connection		Dimensions in mm	
	G	i	SW	$\varnothing d$
63, 80, 100, 160	G 1/2	8.5	27	6 or 8
	G 3/4	9.5	32	6 or 8

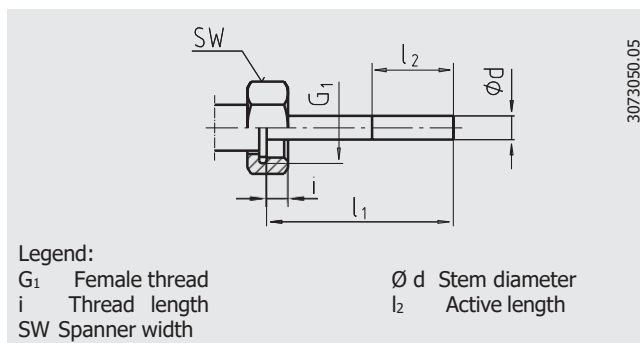

Design 4, compression fitting (sliding on stem)



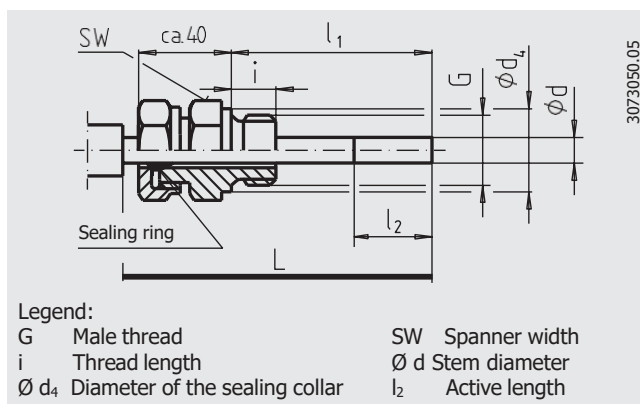

Insertion length $l_1 =$ variable

Length $L = l_1 + 40$ mm

Nominal size	Process connection		Dimensions in mm		
	G	i	SW	$\varnothing d_4$	$\varnothing d$
63, 80, 100, 160	G 1/4 B	8	22	18	6 or 8
	G 1/2 B	14	27	26	6 or 8
	M18 x 1.5	12	24	23	6 or 8
	1/2 NPT	19	22	-	6 or 8
	G 3/4 B	16	32	32	6 or 8
	3/4 NPT	20	30	30	-



Approvals

Logo	Description	Country
	GOST (option) Metrology, measurement technology	Russia
	KazInMetr (option) Metrology, measurement technology	Kazakhstan
-	MTSCHS (option) Permission for commissioning	Kazakhstan
	BelGIM (option) Metrology, measurement technology	Belarus
	UkrSEPRO (option) Metrology, measurement technology	Ukraine
	Uzstandard (option) Metrology, measurement technology	Uzbekistan
-	CRN (option) Safety (e.g. electr. safety, overpressure, ...)	Canada

Certificates (option)

2.2 test report

Approvals and certificates, see website