

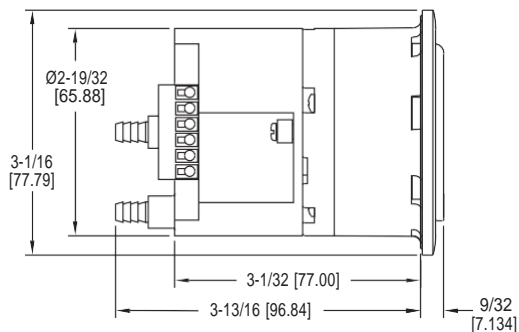

Series MP Mini-Photohelic® Differential Pressure Switch/Gage

Specifications - Installation and Operating Instructions

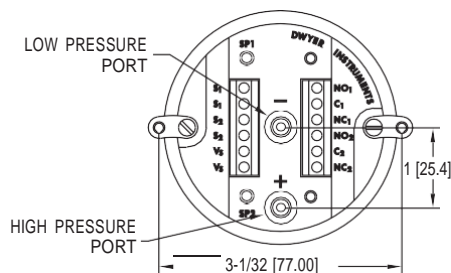

The **Series MP Mini-Photohelic® Differential Pressure Switch/Gage** combines the time proven Minihelic® II differential pressure gage with two SPDT switching setpoints. The Mini-Photohelic® is designed to measure and control positive, negative, or differential pressures consisting of non-combustible and non-corrosive gases. Gage reading is independent of switch operation. Switching status is visible by LED indicators located on the front and rear of the gage.

SPECIFICATIONS

Service: Air and non-combustible, compatible gases.
Wetted Materials: Consult factory.
Accuracy: $\pm 5\%$ of full scale @ 70°F (21.1°C). Gage face mounted in vertical position.
Pressure Limits: 30 psig (2.067 bar).
Temperature Limits: 20 to 120°F (-6.7 to 49°C).
Process Connections: Barbed for 3/16" I.D. tubing (STD); 1/8" male NPT (optional).
Size: 4-1/8" (104.78 mm) depth x 3-1/16" (77.79 mm) diameter.
Weight: 23 oz (652 g).

SWITCH SPECIFICATIONS

Switch Type: (2) SPDT relays.
Electrical Rating: 5A @ 120/240 VAC Resistive; 5A @ 30 VDC.
Electrical Connections: Screw Type Terminal Block. Accepts 22-12 AWG wire.
Power Requirements: 24 VDC / 24 VAC 50/60 Hz 4 watts.
Mounting Orientation: Gage face in vertical position.
Set Point Adjustment: Push Buttons.
Standard Accessories: (2) mounting screws, (1) .050" hex allen wrench.
Agency Approvals: cULus, CE.

INSTALLATION

- 1. Location:** Select a location free from excessive vibration and where ambient temperature will be between 20 to 120°F (-6.7 to 49°C). Pressure sensing lines may be any length necessary without affecting accuracy. However, long runs of tubing will dampen readings slightly and cause an increase in response time. If pulsing pressure or vibration cause excessive pointer oscillation please contact factory for ways to provide additional damping.
- 2. Position:** The Mini-Photohelic® is calibrated and zeroed with gage face in the vertical position at the factory. If the gage is used in any other position, it must be re-zeroed each time the position is changed. Gages with ranges under 5 in. w.c. (1.24 kPa), or equivalent, should be used only in the vertical position unless special calibration was specified when ordering.
- 3. Mounting:** The Mini-Photohelic® is normally mounted before making electrical connections. Terminal blocks are located on the rear of the gage for electrical connections.
 - a. Panel Mounting:** Standard installation for the Mini-Photohelic® mounting is flush through a panel. Allow approximately 1" clearance for pressure tubing and electrical wiring. cut a 2-5/8" (66.68 mm) diameter hole in the panel. Insert the Mini-Photohelic® into the panel, thread #6 mounting screws into the mounting lugs and tighten.

- 4. Zeroing:** Before installation, the Mini-Photohelic® may need to be zeroed before placing into operation. If zeroing is required, you must first remove the zero adjust plug, located near the bottom face of the gage, with a small blade screwdriver. (refer to Figure B.) The zero adjust screw is located directly behind the plug. Use the hex allen wrench supplied and adjust until the pointer is on zero. This must be done with both pressure connections vented to the atmosphere and the gage oriented in the final mounting position. Replace plug. Caution must be taken not to over-tighten the plastic plug when replugging.
- 5. Pneumatic Connections:** To measure positive pressure, connect tubing to port marked "+" and vent "-" port to atmosphere. For negative pressure (vacuum), connect to port marked "-" and vent "+" port to atmosphere. If gage is supplied with 1/8" male NPT connections careful attention must be made not to over-tighten fittings to avoid damage to the gage.

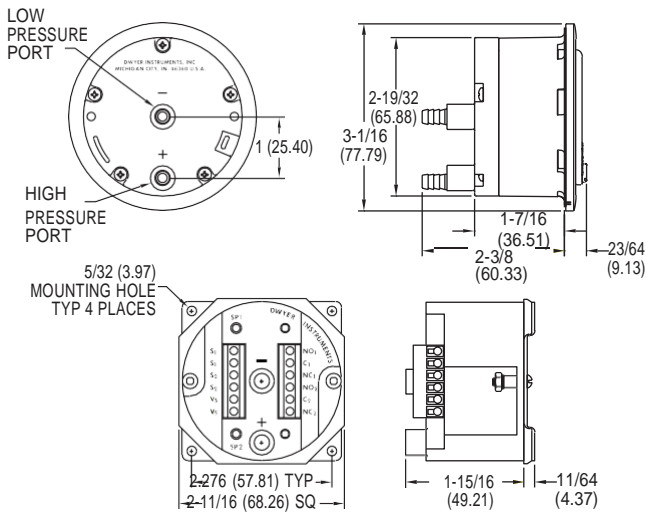

Figure A

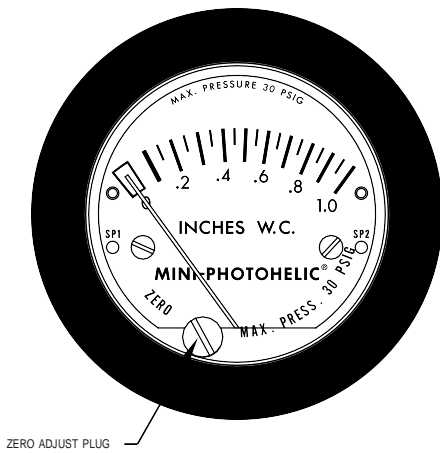
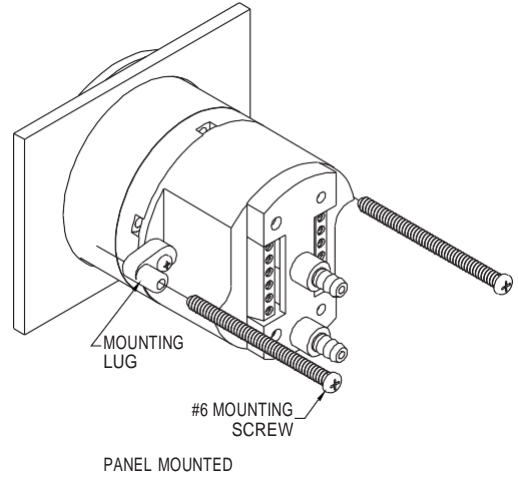
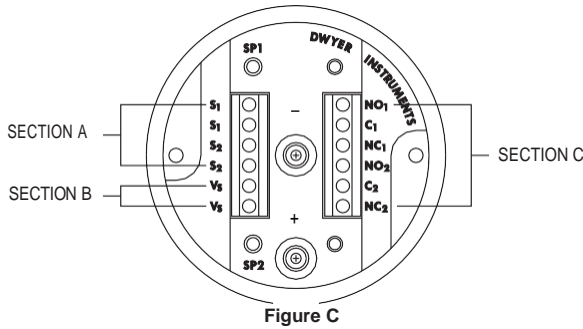

Figure B

6. Electrical Connections: Refer to Figure C for electrical connections located on rear on Mini-Photohelic® Switch/Gage:

- Section A
 - S1 → SP1 Reset Terminal (Do not apply power)
 - S1 → SP1 Reset Terminal (Do not apply power)
 - S2 → SP2 Reset Terminal (Do not apply power)
 - S2 → SP2 Reset Terminal (Do not apply power)
- Section B
 - Vs → 24 VDC / 24 VAC 50/60 HZ
 - Vs → 24 VDC / 24 VAC 50/60 HZ
- Section C
 - NO1 → SP1 Relay NO Contact
 - C1 → SP1 Relay Common Contact
 - NC1 → SP1 Relay NC Contact
 - NO2 → SP2 Relay NO Contact
 - C2 → SP2 Relay Common Contact
 - NC2 → SP2 Relay NC Contact



8. Circuit Style: The Mini-Photohelic® Switch/Gage is available with several factory installed optional circuits. They are identified by the label shown in Figure D. This label is mounted on the upper side of the main pressure housing.

The letter H denotes a circuit in which the relay can be made to latch or remain energized after pressure increases above its setpoint.

The letter L denotes a circuit in which the relay can be made to latch or remain de-energized after pressure decreases below its setpoint.

Two letters are required to fully identify a dual setpoint unit. Thus, circuit style HH, which is standard, is a dual setpoint circuit which has provisions for latching on pressure increase to either setpoint. Circuit styles may be used with either setpoint stated above.

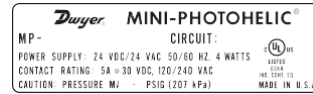

Figure D

9. Dual Setpoint Automatic Reset: Circuit style HH is used for simple on-off switching applications. To place in service, connect load circuits to the appropriate terminals in Section C (Fig. C) for SP1 relay and SP2 relay. No connections are required in Section A.

Section A contains external connections to the holding circuit for manual reset applications. The function and use of these connections varies somewhat depending on the circuit style of the instrument. See steps 7 and 9 for details.

Caution: Do not apply electrical current to terminals in Section A.

Section B contains the power connections for the control unit. Standard unit is designed to operate on 24 VDC / 24 VAC 50/60 HZ.

Caution: Do not apply 120 / 240 VAC to the power connections.

Section C contains connections for SP1 and SP2 relays. Connections are marked on the rear of the instrument.

7. Setpoint Calibration: Setpoint calibration is easily attained by actuating the push buttons located on the rear of the instrument. Pushbuttons are labeled SP1 and SP2. To set the setpoint SP1, apply pressure where you require the SP1 relay to energize. Press pushbutton marked SP1 on the rear of the instrument, SP1 LED located on the front and rear of the instrument will flash several times. When LED stops flashing calibration is complete. Repeat the same steps above for SP2 relay.

10. Dual Setpoint Manual Reset: Circuit style HH may also be used for manual reset applications where it is required to maintain contact on either relay following pressure increase above its setpoint. Load or signal connections are made to the appropriate terminals in Section C (as in step 8). Connect terminals in Section A through normally closed switches or pushbuttons as shown in Figure E. Use “dry-circuit” type switches such as Dwyer Part No. A-601 with palladium, gold, etc. or rotary wiping action type contacts is recommended.

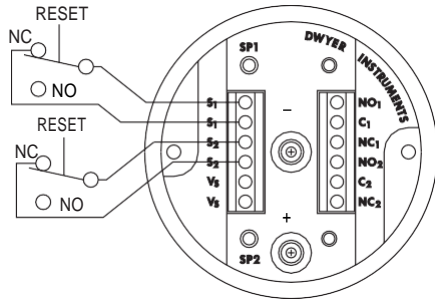

Figure E

Circuit style LL is used for manual reset applications where it is required to maintain contact on either relay following pressure decrease below the setpoint. Load or signal connections are made to the appropriate terminals in section C (as in step 8). A normally open type manual reset switch such as Dwyer Part No. A-601 is connected to the terminals in Section A. The circuit must be “armed” by momentarily energizing the switch while the pointer is to the right of the setpoint. From that point on, the circuit will latch on pressure decrease below the setpoint and remain latched on pressure increase until manually reset with the optional switch.

11. High Low Limit Control - Dual Setpoint: Standard circuit style HH may be used to control various fans, dampers, pumps, etc..., between the setpoints of a Mini-Photohelic® Switch/Gage. To accomplish this, use one setpoint relay to reset the other as shown in the wiring diagram Figure F. In this typical application, the load would be connected to the N.C. contacts (NC2) of the right setpoint relay SP2. The N.O. contacts of SP1 relay would be connected to the S2 reset terminals on the rear of the instrument. On pressure rise to the right setpoint relay SP2, the relay would pull-in and hold even though the pressure might fall below that setpoint. If the pressure continued to fall to the left of setpoint SP1, then SP2 relay would be automatically DE-ENERGIZED, returning to its normal position and in so doing, open the reset terminal S2. The right setpoint relay SP2 would thus be reset and the cycle could repeat.

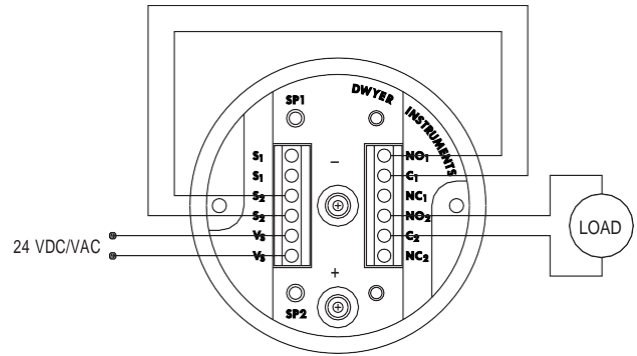

Figure F

12. Dual Setpoint Special Purpose Circuits: Circuit Style LL may be used where manual reset following maintained contact on pressure decrease to either setpoint is required. Circuit HL and LH are combination units. For special combinations of features and special units consult factory.

13. Failure Mode: The Mini-Photohelic® circuit design provides certain protection in the event of a loss of electrical power. Both relays will de-energize upon loss of power.

MAINTENANCE AND SERVICE

Dwyer Mini-Photohelic® Switch/Gages are precision instruments, expertly assembled and calibrated at the factory. They require no lubrication or periodic servicing. If the interior is protected from dust, dirt, corrosive gases and fluids, years of trouble-free service may be expected. Zero adjustment should be checked and reset occasionally to maintain accuracy.

Upon final installation of the Series MP Mini-Photohelic® Differential Pressure Switch/Gage and the companion receiver, no routine maintenance is required. A periodic check of the system calibration is recommended. The Series MP is not field serviceable and should be returned if repair is needed (field repair should not be attempted and may void warranty). Be sure to include a brief description of the problem plus any relevant application notes. Contact customer service to receive a return goods authorization number before shipping.